



Consumer Packaging



SEALPACK ROUND TALL SERIES
8 OZ. / 250 ML TO 32 OZ. / 1 L

FOOD MANUFACTURING AND PROCESSING

Packaging that stands out.

SealPack Round Tall

Extend the shelf life of your products



Extend the shelf life of your products without food preservatives. All SealPack Round series containers are HPP ready.

Features

- Film-sealable
- Withstands high pressure pasteurization*
- Enlarged rim that provides a safe grip
- Photo-quality IML decoration
- Dry offset print ready
- Optional flip hinge lid
- 100% recyclable polypropylene

Benefits

- Easy transition from other existing products
- Microwave and dishwasher safe
- HPP-ready packaging

PACKAGING THAT STANDS OUT

Designed to differentiate your brand from the competition while protecting the freshness and unique taste of your product. Ideal for deli and dairy products. Improve your customers experience with our optional reclosable pouring lid, perfect for dispensing grated cheeses or other crumbled products,

For every need

Dairy

Cultured dairy, cheese, spreads, shredded cheese.

Deli

Salads, soups, sauces, dips, other refrigerated products.



Mod.: 22520
8 oz. - (250 ml)
4.59" (W) X 1.95" (H)



Mod.: 23120
10 oz. - (310 ml)
4.59" (W) X 2.36" (H)



Mod.: 23520
12 oz. - (350 ml)
4.59" (W) X 2.72" (H)



Mod.: 24020
14 oz. - (425 ml)
4.59" (W) X 2.92" (H)



Mod.: 25020
16 oz. - (500 ml)
4.59" (W) X 3.49" (H)



Mod.: 27520
24 oz. - (750 ml)
4.59" (W) X 4.02" (H)



Mod.: 21120
32 oz. - (1 L)
4.59" (W) X 5.28" (H)

SealPack Round Tall Specifications

www.iplglobal.com

1-800-647-0602

CONTAINERS

Product Code	Model	Decoration Options†		Brimful Capacity		Approx. Weight		Overall Height ^A		Overall Diameter ^B		Items Per Box	Boxes Per Pallet	Items Per Pallet
		IML	Offset	US fl.oz.	ml	oz.	g	in.	mm	in.	mm			
22520	8 oz. / 250 ml	✓ W/B	✓ W	11.16	331	0.32	9.2	1.95	49.5	4.59	116.6	1,020	20	20,400
23120	10 oz. / 310 ml	✓ W/B	✓ W	13.19	390	0.39	11.1	2.36	59.8	4.59	116.6	1,000	20	20,000
23520	12 oz. / 350 ml	✓ W/B	✓ W	15.92	471	0.45	12.8	2.72	69.0	4.59	116.6	960	20	19,200
24020	14 oz. / 425 ml	✓ W/B		16.91	500	0.47	13.3	2.92	74.0	4.59	116.6	980	20	19,600
25020	16 oz. / 500 ml	✓ W/B	✓ W	19.58	579	0.53	15.1	3.49	88.5	4.59	116.6	920	20	18,400
27520	24 oz. / 750 ml	✓ W		26.21	775	0.74	20.9	4.02	102.1	4.59	116.6	600	20	12,000
21120	32 oz. / 1 L	✓ W		33.81	1,000	1.02	29.0	5.28	134.2	4.59	116.6	380	20	7,600

* Ask for our HPP Guide to know more about HPP use and limitations on this series

LIDS

Product Code	Associated Containers Code	Decoration Options		Approx. Weight		Height ^A		Diameter ^B		Items Per Box	Boxes Per Pallet	Items Per Pallet
		IML	Offset	oz.	g	in.	mm	in.	mm			
20120	All sizes of containers	✓	✓	0.26	7.4	0.29	7.4	4.63	117.6	1,140	24	27,360
20121	Lid with hinge / pour tab - All sizes of containers	✓		0.32	9.0	0.38	9.7	4.63	117.6	1,005	24	24,120

Color Options

Base Colors	Standard Colors	Other Colors
Natural 000	Yellow 012	Available on request
White 001	Orange 021	
Clear 002	Red 485	
	Green 377	
	Blue 293	
	Black 099	

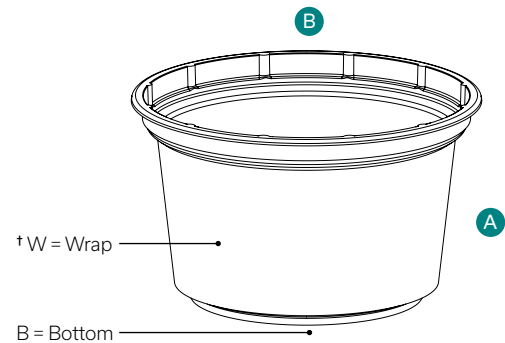

Certifications

The raw materials used are tested according to ASTM standards for polymers, are approved for food contact and meet FDA (Food and Drug Administration, USA) and HPB (Health Protection Branch, Canada) regulations. Our facilities and rigorous quality control processes have earned us certification under the following standards: ISO 9001, HACCP, IMS, SQF, C-TPAT & ISO 14001 registered management system.

Recommendations

Handling conditions vary from customer to customer. We recommend validating your processes (filling, conveying, warehousing and any others that might affect the purchased part) prior to use. Product usage temperature is between -9.4°F (-23°C) and 179.6°F (82°C) depending on resin grade.

Warranties

Some chemicals can affect the integrity of the product. Any product requiring a Safety Data Sheet (SDS) has to be submitted and approved by IPL. If buyer fails to adhere to this clause, the related product guarantees will be void.

Contact your IPL representative to ensure you have the most recent information.

The information presented herein was prepared at IPL Inc. by qualified technical personnel. To IPL's knowledge, it is true and accurate. However, the information and recommendations are provided for these products with the understanding that the customer will independently determine that the product is suitable for the intended use, and that such use, complies with all applicable laws and regulations. The data represents typical values submitted only for the user's information and consideration and does not constitute a warranty of any kind.