



Consumer Packaging



TRUSTPACK™
64 OZ. / 2 L TO 84 OZ. / 2.5 L

FOOD MANUFACTURING AND PROCESSING

Safety, ease of use and
added branding value.

TrustPack™

Increasing product safety and shelf appeal



We don't just make containers, we understand the importance of reaching and attracting your customers at the point of purchase.

Features

- Intuitive pull-tab, single-motion lid opening
- Easy handling with built-in handles
- Stable in a stack
- Tamper-evident system & film-sealable container
- 100% recyclable polypropylene

Benefits

- Up to 40% more containers on a pallet vs. round
- Added branding value through photo-quality IML
- Microwave and dishwasher safe

SAFE, CONVENIENT & GREAT BRANDING VALUE

A tamper-evident system that offers a unique integrity indicator, increasing product safety while adding shelf appeal.

Ideal for a wide range of application such as dairy, deli, confectionary, nutritional supplements, detergents, etc. Trustpack containers are ideal for retail and wholesale food markets, restaurants, and food service businesses.

Now also available with a lid option for products requiring the application of a film seal.

For every need

Dairy

Cultured dairy, cheese, spreads, shredded cheese.

Deli

Salads, soups, sauces, dips, other refrigerated products.

Other

Grocery, club store, food service, hardware, household cleaning, pet food, lawn & garden.



Mod.: 22064
64 oz. - (2 L)
6.68" (W) X 4.95" (H)



Mod.: 22564
84 oz. - (2.5 L)
6.57" (W) X 5.90" (H)

CONTAINERS

Product Code	Model	Decoration Options*		Under Lid Capacity		Approx. Weight		Overall Height	A	Overall Width	B	Items Per Box	Boxes Per Pallet	Items Per Pallet
		IML	Offset	US fl.oz.	ml	oz.	g	in.	mm	in.	mm			
22064	64 oz. / 2 L	✓	W/P	74.05	2,190	2.29	64.8	4.95	125.7	6.68	169.7	150	21	3,150
22564	84 oz. / 2.5 L	✓	W/P	88.25	2,610	2.72	77.0	5.90	149.9	6.57	166.8	144	21	3,024

LIDS

Product Code	Associated Containers Code	Decoration Options		Approx. Weight		Height	A	Width	B	Items Per Box	Boxes Per Pallet	Items Per Pallet
		IML	Offset	oz.	g	in.	mm	in.	mm			
20163	Film Seal version / All sizes of containers	✓		0.74	21.0	0.57	14.4	6.47	164.4	636	28	17,808
20164	Regular Tamper-Evident / All sizes of containers	✓		0.69	19.5	0.38	9.60	6.46	164.1	600	28	16,800

Color Options

Base Colors	Standard Colors	Other Colors
Natural 000	Yellow 012	Available on request
White 001	Orange 021	
Clear 002	Red 485	
	Green 377	
	Blue 293	
	Black 099	

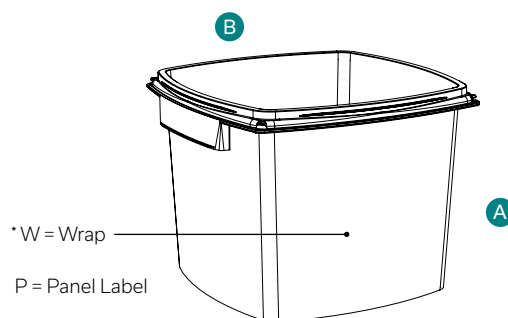

Certifications

The raw materials used are tested according to ASTM standards for polymers, are approved for food contact and meet FDA (Food and Drug Administration, USA) and HPB (Health Protection Branch, Canada) regulations. Our facilities and rigorous quality control processes have earned us certification under the following standards: ISO 9001, HACCP, IMS, SQF, C-TPAT & ISO 14001 registered management system.

Recommendations

Handling conditions vary from customer to customer. We recommend validating your processes (filling, conveying, warehousing and any others that might affect the purchased part) prior to use. Product usage temperature is between -9.4°F (-23°C) and 179.6°F (82°C) depending on resin grade.

Warranties

Some chemicals can affect the integrity of the product. Any product requiring a Safety Data Sheet (SDS) has to be submitted and approved by IPL. If buyer fails to adhere to this clause, the related product guarantees will be void.

Contact your IPL representative to ensure you have the most recent information.

The information presented herein was prepared at IPL Inc. by qualified technical personnel. To IPL's knowledge, it is true and accurate. However, the information and recommendations are provided for these products with the understanding that the customer will independently determine that the product is suitable for the intended use, and that such use, complies with all applicable laws and regulations. The data represents typical values submitted only for the user's information and consideration and does not constitute a warranty of any kind.